

AP Inbox

Go paperless and speed up the processing of supplier invoices with our automated AP Inbox. Route emails containing invoices directly into your AccountsIQ company inboxes, ready for checking.

Many finance teams still operate without digital document management systems and struggle to deal with ever growing volumes of supplier invoice paperwork. Time is spent organising, copying, filing, and then retrieving invoices when needed, adding little or no value.

Paper invoices and the de-centralised delivery of digital invoices to teams outside finance results in bills getting lost or misplaced leading to late payments and accounts being put on hold. In the worst cases finance only get to hear that an invoice exists when the supplier is chasing for payment.

The stress on hard-pressed AP teams in growing businesses is real. Burn-out creates damaging high staff turnover in these important finance roles seeing knowledge and experience lost. The volume of monotonous re-keying and the criticisms from colleagues who perceive AP as being a bottleneck add up to a challenge for job satisfaction.

Late payments threaten good relationships with suppliers on whom you may rely for critical goods and services. The cost, and disruption of making urgent, ad hoc payments to key suppliers can be significant and is unnecessary.

The answer to all these issues is the paperless AP Inbox from AccountsIQ.

AP Inbox lets you upgrade critical elements of your current processes to address these challenges within ongoing finance operations. AP Inbox is the first step towards end-to-end automation of your accounts payable process.

Benefits of AP Inbox

Process invoices quicker - reduce the amount of input and work through the inbox fast, online.

Reduce labour costs - centralise all inbound invoices. Spend less time chasing staff.

Minimise expensive errors - lose less invoices. Ensure all are checked & approved before paying.

Lower invoice processing costs - less time sorting, copying, filing, chasing & answering phones.

Go paperless with AP Inbox.

At a glance

- Paperless supplier invoice processing
- Auto-create new invoices
- Header level data capture
- Split screen display for fast data entry and validation
- Currency recognition
- Automatic supplier identification
- Dedicated email address per AccountsIQ company
- Complements existing AccountsIQ invoice processing

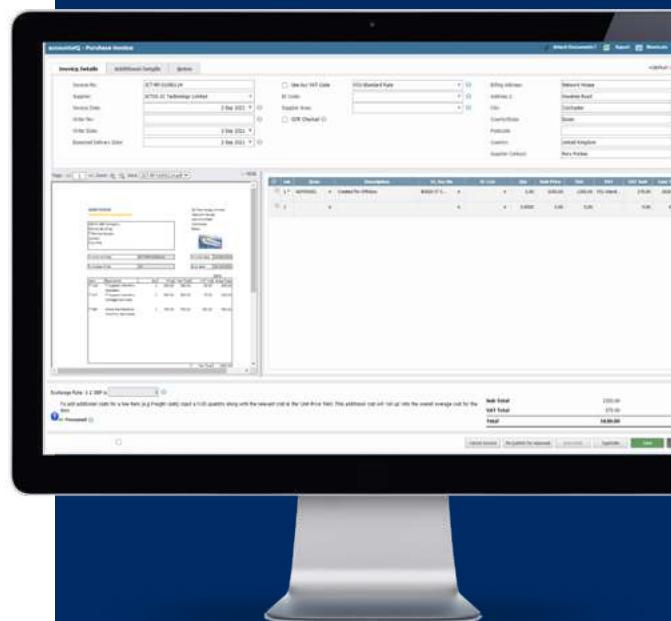

AP Inbox Process

The AP Inbox enabled process flow takes PDF invoices emailed from suppliers and executes steps to identify the documents as invoices and then to extract data per the configuration choices.

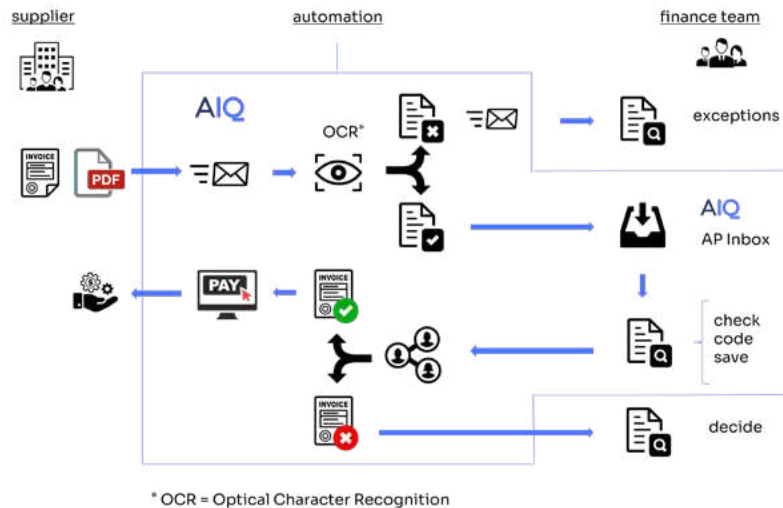

Key features

Process invoices received by email direct from suppliers and those forwarded internally.	VAT rates are dynamically validated with identified tax rate within company settings.	Auto-create invoices in AP Inbox with one line for simple completion
OCR capture of each PDF invoice processed by the service.	Checked invoices move from AP Inbox to Item Invoices tray for subsequent tracking.	Currency recognition. Currencies must exist in the company or will be entered with base currency.
Automatic supplier identification (email, bank details, company name, VAT registration number)	Export AP Inbox to Excel for quick analysis of invoices awaiting processing.	Extracts invoice number/reference and Net, VAT, Gross values.
Document-only extraction option does not perform OCR but places documents in transactions for manual keying, with one line auto-generated.	Interacts with existing AccountsIQ functionality for manager approval by supplier.	Duplicate invoice number detection at supplier level with fallback email for exceptional review.
Split screen display. PDF invoice on the left with header and transaction lines above and to the right.	Non-invoice documents sent to configurable fallback email for exceptional review.	Operator marks each invoice "Checked" to progress to approval or posting
Remove duplicate entries from the AP Inbox by cancelling invoices.	Rapid deployment by company using user menu profiles so only authorised users can access.	

Get in touch to discuss your Cloud accounting needs:

UK: +44 (0)203 598 7350
Ireland & Rest of the World: + 353 (1) 707 44 90

sales@accountsIQ.com
www.accountsIQ.com